

# Flue Gas Fan KA I Junior

for small heating systems and furnaces

**Stainless steel**  
Industrial quality

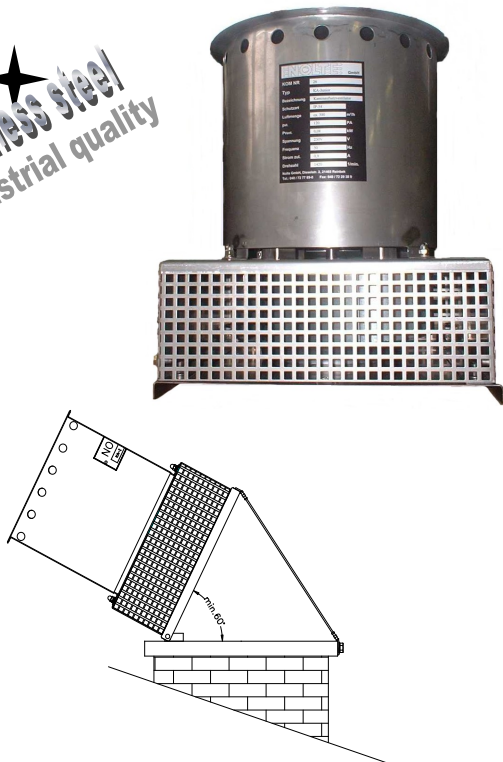

## Chimney top fan

The chimney fan KA I Junior is our smallest flue gas fan. It is mounted on the chimney head and blows flue gas, if there is insufficient natural draft, by means of vacuum safety to the chimney cap. Unhealthy and dirty combustion products do not enter living rooms, basements or conservatories.

The fan casing and the fan are made of stainless steel and therefore guarantee a high protection against corrosion.

The fan motor is a continuously variable, temperature-protected standard motor with temperature monitoring by thermal contacts.

The fan is easy to assemble. He is pre-wired with a heat-resistant connection cable in a metal flexible duct.

For chimney cleaning it can be tilted without tools on the chimney head.

## Operation note

Before use and during the entire period of operation of the hearth, the fan must be switched on!

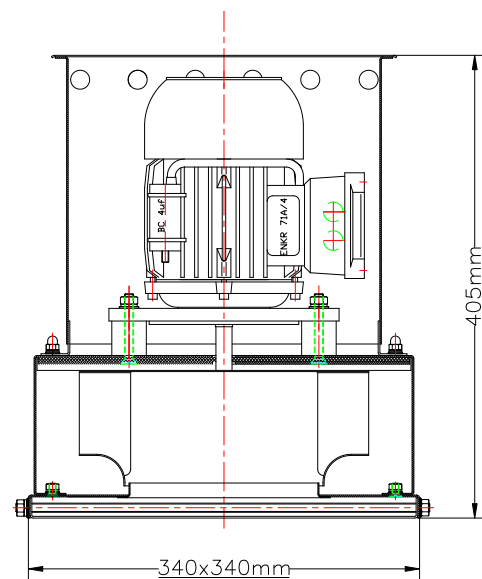
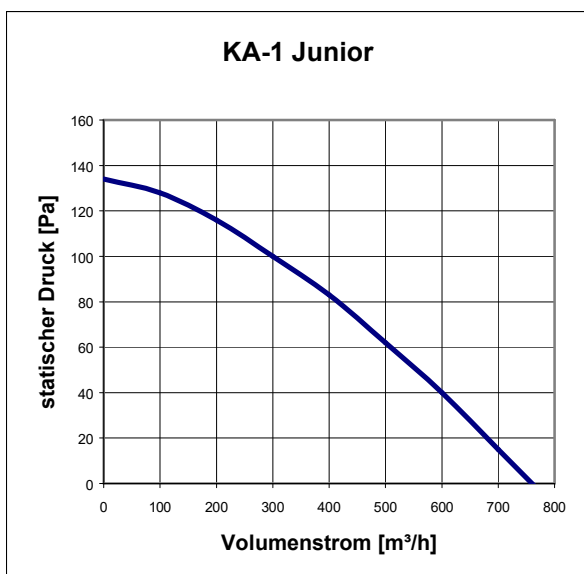

Type	no. of revolutions	feed volume at 100Pa	voltage	current max.
KA I Junior	max. 1.420U/min	300m³/h	80 bis 230V/50Hz	max. 0,9A



### Maintenance switch

The maintenance switch is required for maintenance and cleaning. It is installed directly in the immediate vicinity of the fan and can be locked to prevent inadvertent operation. The switch disconnects the fan poles (incl. the thermal contacts) from the mains.



### 5-step speed controller with motor protection

It is recommended to use a speed controller, since the fan must always run when a fire is burning. This speed controller, you can adjust the speed of the fan by means of rotary knob in five stages and thus adjust it to required vacuum optimally to your system. There are also variable transformers used.

Simultaneously, a motor protection switch is integrated. Once the thermal contacts trigger in the engine, the fan is disconnected from the mains. The motor protection switch is reset by holding the rotary knob for 10sec. to "0". After that, the fan can be adjusted with the rotary knob to the desired speed level again.

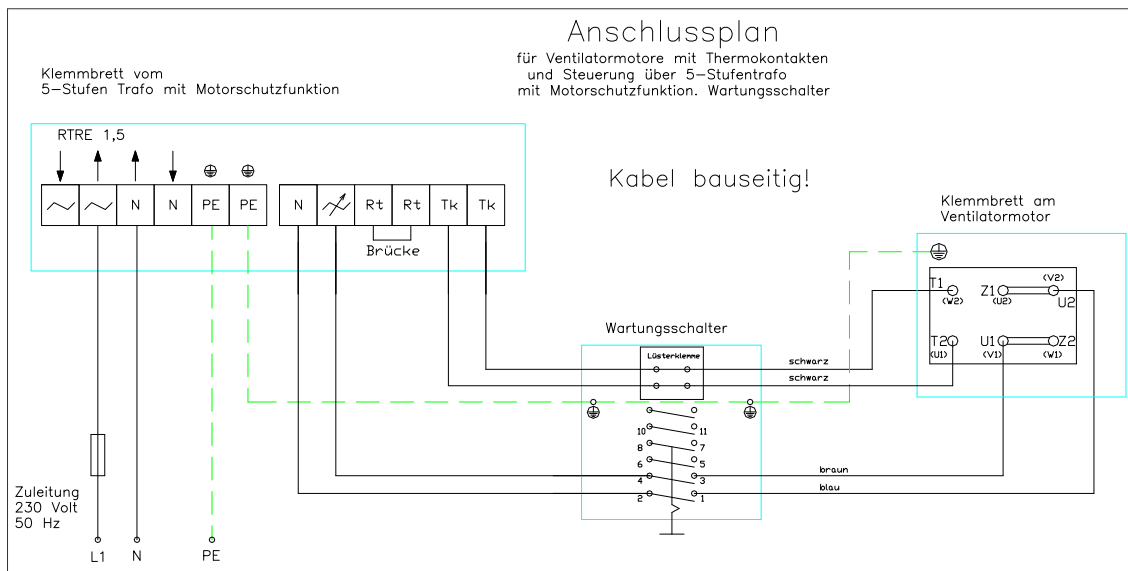

**Alfred Nolte GmbH ♦ Dieselstraße 2 ♦ 21465 Reinbek**  
Tel. 040 / 727 789-0 ♦ Fax 040 / 727 789-26 ♦ E-Mail: [info@alfred-nolte.de](mailto:info@alfred-nolte.de)  
Please visit our website [www.alfred-nolte.de](http://www.alfred-nolte.de)

**Rechtsform**  
GmbH  
**Sitz der Gesellschaft**  
Reinbek

**Handelsregister**  
Lübeck HRB 15687 HL  
**USt-ID-Nr.**  
DE 305 473 435

**Geschäftsführer**  
Niels Albers  
**Postanschrift**  
Dieselstraße 2, 21465 Reinbek

**E-Mail**  
[info@alfred-nolte.de](mailto:info@alfred-nolte.de)  
**Homepage**  
[www.alfred-nolte.de](http://www.alfred-nolte.de)

**Telefon**  
040/727 789 - 0  
**Telefax**  
040/727 789 - 26

\\SERVER\Daten\DOC\Prospekte\Kaminaufsatzventilator\KA-Junior-Flyer E 160709.doc