



Your partner for air-technical and complementary equipment, individual equipment, fans, accessories

<p>Tailormade air ventilation machinery</p>	
<p>Stainless steel working e.g. for food processing- and pharma-industry</p>	
<p>Special machinery for food processing</p>	

As experts for stainless steel production, we produce equipment and accessories for hygienic areas, the pharmaceutical industry, the food industry according to your ideas and needs.

We offer special systems for the mobile salting, coating, spicing or flavouring. These machines can be designed as cooling systems on the basis of the same machine, which conveys the product at the same time by means of the spiral.

Our portfolio includes all components of the air and heating technology: Fans and special fans for high pressure, single - or multistage, and portable models, as well as versions for high temperature. We also make individually for you heat exchangers, ducts, vapour intakes, deflector - and rain hoods, as well as ventilation systems- and exhaust air systems with or without filter. Sound-absorbing and insulating components are also part of our portfolio.

In the segment locksmith's shop, metal fabrication and sheet metal construction we make a wide range of components and systems, painted or galvanized, from stainless steel or especially corrosion-resistant stainless steel. Even laboratory workplace with washbasin and extraction of stainless steel, a conveyor system with built-in scale or a cover. Also facade panels, safety guards, containers and trolleys are part of our range. There would be many other examples. But it would be even nicer if we talked directly about what we can do individually for you.

Examples from our portfolio

Components for air- and heating- technology

Fans: Axial-, radial-, high temperature- and special fans

Electric Air Heaters made from sheet metal, zinc coated or stainless steel

Heat exchanger made from steel, zinc coated or stainless or Cu/Al

Air ducts, tubes and molded parts made from steel or stainless steel, or plastic

Vapour suction hoods for kitchen and laboratories as well as deflector- and rainhoods

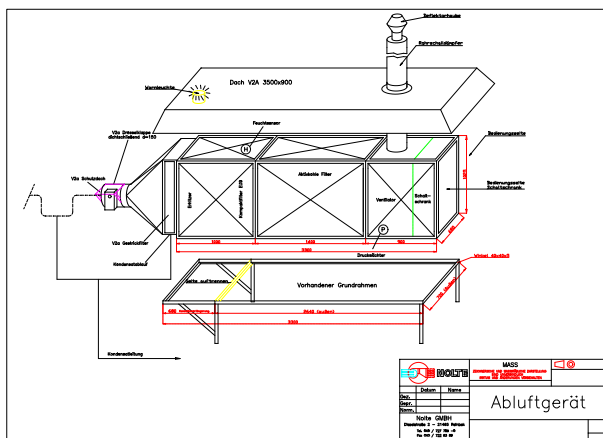

Axial fan



E-Air Heater

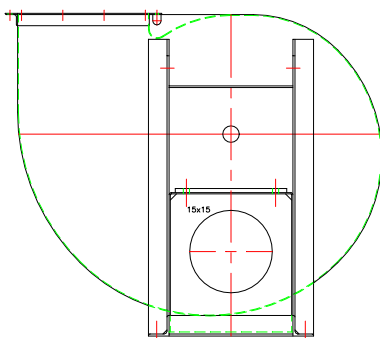

Cyclone



Filter

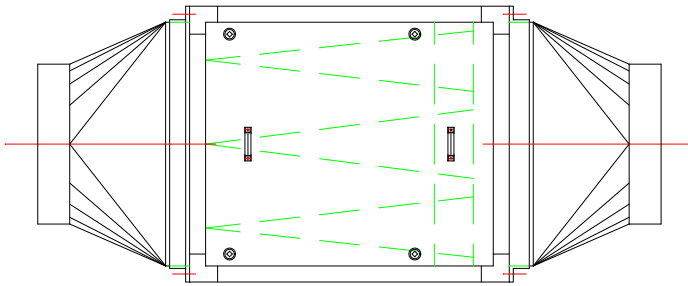

Special fans

- High pressure fans
- Conveyor technology fans
- High temperature fans

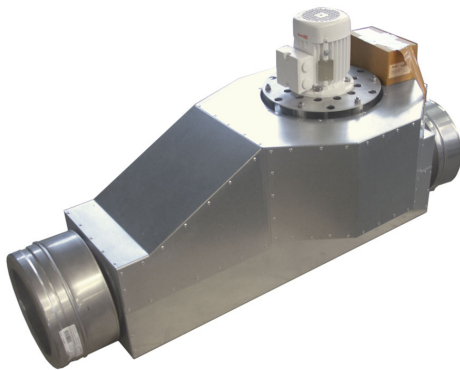
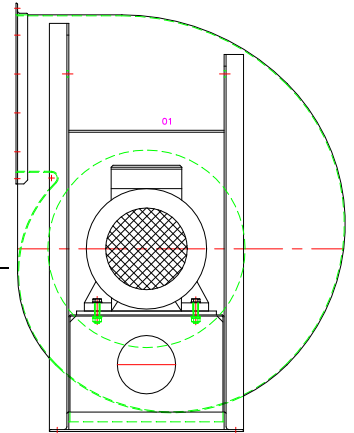

Steel and stainless steel working

locksmith work / steelconstruction / sheet metal designs:

We are processing sheet metal up to 6 mm thickness and 3 m length, from steel, stainless steel, NI-metals
working of profiles of any kind



Component for salting / -spicing of food: Barrel with agitator, made from stainless steel



Conveyor with integrated scale

Our service



Laboratory workplace with suction,
completely made from stainless steel.



conveyor, stainless steel

Service

Professional and innovative: Research and development in our own laboratory

Our highly qualified engineers, technicians and scientists research and develop market-oriented instruments and equipment in our own laboratory. Here they demonstrate the practicability of processes developed. Then, our designers design the machine in the size required for the professional use.

For you on the spot: Consulting and planning in your company

You have the need to work with customized, energetically optimized systems and equipment for your operation? The prerequisites and the necessary implementation steps would be the best to be clarified at your site. That's why we gladly come to you.

Everything from one source: Experienced contact person in each stage of the project

Whether in development and design, production and assembly: With us you encounter in each stage of the project an experienced contact person. So you can be sure that we professionally support you at every step and at the same time all agreements and work optimally run together.

For the perfect start: Professional installation of your equipment

It is a matter of course for us to take your plant together with your employees on site in operation. We guide you step by step and also the operational safety and minimum energy consumption of your new system at a glance.

Masters and engineers: Qualified professionals in action

In manufacturing, construction, and maintenance of your equipment and systems, rely on the competence of professionally qualified staff. From individual products to high-volume process technology-savvy professionals with extensive know-how work for us on the products you need.

Please ask for our special product brochures

Alfred Nolte GmbH ♦ Dieselstraße 2 ♦ 21465 Reinbek
Tel. 040 / 727 789-0 ♦ Fax 040 / 727 789-26 ♦ E-Mail: info@alfred-nolte.de
[Please visit us on our website www.alfred-nolte.de](http://www.alfred-nolte.de)